

# РУХОМИЙ СКЛАД І ТЯГА ПОЇЗДІВ

UDC 004.92:621.01

L. O. NEDUZHA<sup>1\*</sup>, A. O. SHVETS<sup>2\*</sup>

<sup>1\*</sup>Dep. «Building Mechanics», Dnipropetrovsk National University of Railway Transport named after Academician V. Lazaryan, Lazaryan St. 2, Dnipropetrovsk, Ukraine, 40910, tel. +38 (067) 810 51 65, e-mail nlorhen@i.ua, ORCID 0000-0002-7038-3006

<sup>2\*</sup>EDSD MBCSS, Dnipropetrovsk National University of Railway Transport named after Academician V. Lazaryan, Lazaryan St. 2, Dnipropetrovsk, Ukraine, 49010, tel. +38 (050) 214 14 19, e-mail angela\_shvets@ua.fm, ORCID 0000-0002-8469-3902

## APPLICATION OF APM WINMACHINE SOFTWARE FOR DESIGN AND CALCULATIONS IN MECHANICAL ENGINEERING

**Purpose.** To conduct the research at all stages of design, development, operation, residual operation life determination, namely, preliminary study, action principle choice, design of draft and technical projects, their optimization, preparation of design documentation and control information for automated production, comprehensive engineering analysis, it is required to use the latest computer technologies. Their use can not only present data and information in some way, but also gives the opportunity to effectively and directly interact with the information object that is created or demonstrated. **Methodology.** To perform engineering calculations associated with the analysis of the strength of machines, mechanisms, constructions one uses both analytical and numerical methods in practice. The most common method for analysing the stress-strain state of object models, obtaining their dynamic and stability characteristics at constant and variable modes of external load is the finite element method, which is implemented in many famous and widespread software products, providing strength calculation of models of machines, mechanisms and structures. **Findings.** The use of modern software for designing machine parts and various types of their joints and for strength analysis of structures is justified. Colour charts for distribution of stresses, displacement, internal efforts, safety factor and others allow accurate and quick identification of the most dangerous places in the structure. The program also provides an opportunity to «look» inside the elements and see the resulting distribution of internal force factors. **Originality.** The paper considered the aspects, which are unexplored at present, associated with the current state and prospects of development of industrial production, the use of software package for design and calculations in the mechanical industry. The result of the work is the justification of software application for solving problems that are aimed at using research findings for various practical tasks in specific fields of mechanical engineering. **Practical value.** Compared with other software systems, popularity of the considered one is explained by easy mastering of the system, quick implementation both in training and in production process. The organizational structure, «friendly» graphical interface and accessible language make learning and use of the program very convenient. These and other factors actually reduce the time for project implementation, emphasize the relevance and the practical importance of the software system, which is appreciated by its users.

*Keywords:* modern software package; mechanical engineering; machine; mechanism; structure; engineering calculation; strength

### Introduction

Industrial production is one of the main parts of the national economy of any country that provides vital interests, economic security, social and cultural level of the population, determines the technical and economic potential [15, 18].

One of the most complicated and most critical industries is machine building. Its share in total industrial production and the size of export of engineering products are the indicators that most accurately determine the general level of economic development. In the modern context mechanical engineering plays

РУХОМИЙ СКЛАД І ТЯГА ПОЇЗДІВ

an important role in accelerating scientific and technological progress because it largely determines its general directions and is the foundation of the economy, plays a crucial role in creating and updating its material and technical base.

Mechanical engineering is the leading sector, whose share by value is about 1/3 of the world industrial production (Fig. 1, a) [15].

a

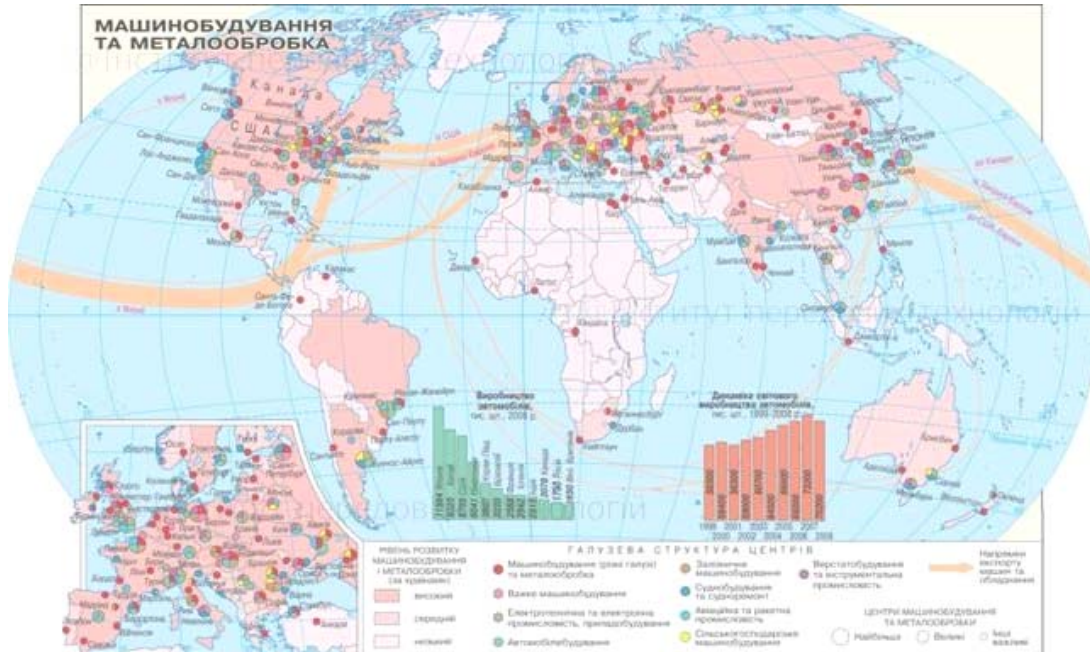

b



Fig. 1. State of development geography of:  
a – mechanical engineering and metalworking of the world; b – engineering industries of Ukraine

## РУХОМИЙ СКЛАД І ТЯГА ПОЇЗДІВ

Inter-branch economic complex of Ukraine integrates the system of research, design and technological organizations, enterprises, whose products have common economic purpose, production and operational similarity. Location of enterprises of various engineering branches depends on such factors as the level of science; availability of appropriate human resources, raw materials, consumer (Fig. 1b). [18].

### Purpose

Nowadays, on the days of rapid development of computer information technology, no sector of the national economy can do without modern software systems to perform complex engineering calculations and to make the right decisions. To conduct the research at all stages of design, development, operation, residual operation life determination, namely, preliminary study, action principle choice, design of draft and technical projects, their optimization, preparation of design documentation and control information for automated production, comprehensive engineering analysis, it is required to use the latest computer technologies. Their use can not only present data and information in some way, but also gives the opportunity to effectively and directly interact with the information object that is created or demonstrated. These and many other problems are solved with the help of modern information technologies that confirms the relevance of their application.

*Topicality.* In today's world the computer information technology is rapidly penetrating into all spheres of activity – today the successful are only those sectors of the national economy, only those educational institutions or commercial companies that own the latest computer technologies. Over the past decade they have undergone such a global expansion, that it is hard to imagine human life and production activities without them.

At this stage you can easily give examples of the use of information technologies in all areas: from education to management. Significant progress is achieved in the field of education due to introduction of appropriate computer technology that can make the knowledge-gathering process available, remote, flexible, individual [13]. That is also true of mechanical engineering, including the transport one (Fig. 2), as the complexity of the engineering calculations and making the right decisions requires increasing use of advanced computer systems and technologies [1, 7]. Their use can not only present data and information in some way, but also gives the opportunity to effectively and directly interact with the information object that is created or demonstrated. These and many other problems are solved with the help of modern information technologies that confirms the relevance of their application.

a





## РУХОМИЙ СКЛАД І ТЯГА ПОЇЗДІВ

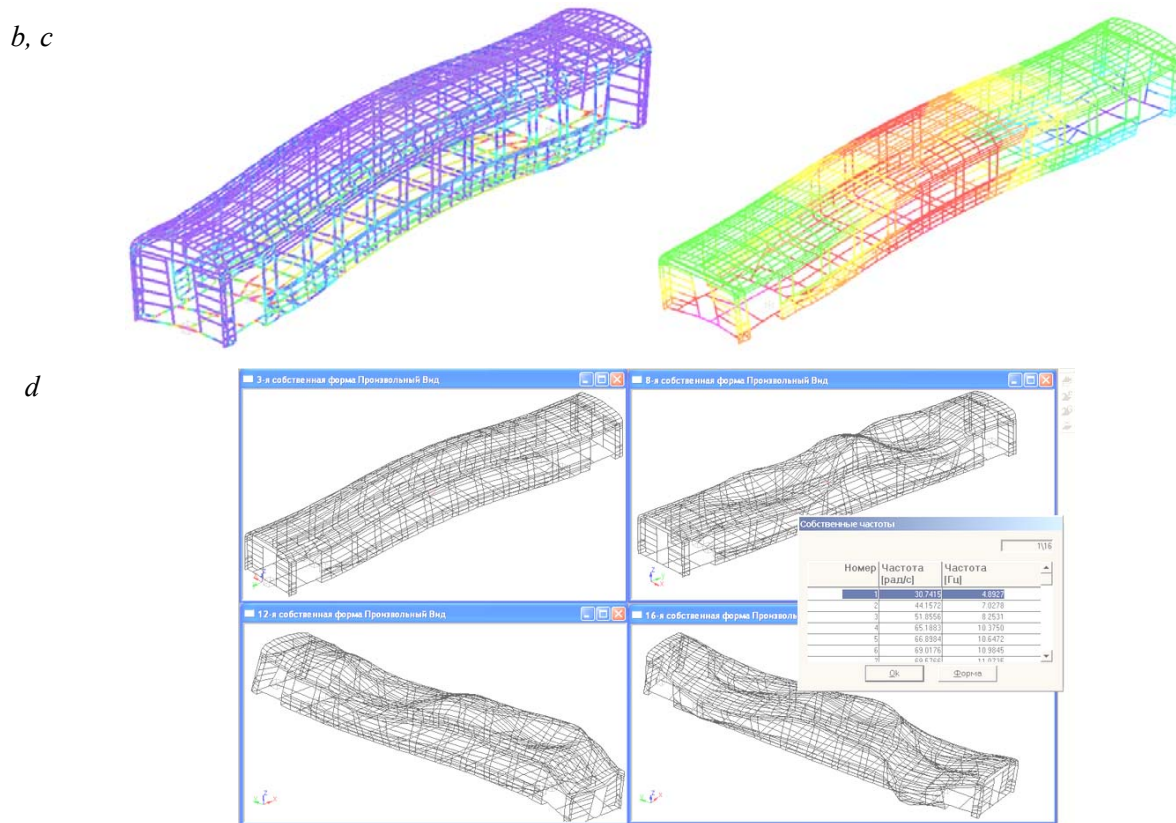

Fig. 2. Multiple-unit car body:

*a* – calculation model; *b* – chart of the stress-strain state;*c* – chart of the total linear displacement distribution; *d* – chart of the frequency of free oscillations

Software packages for various purposes skillfully use modern computer technology (mathematical modelling, knowledge and data bases, computer networks, expert systems and decision-making systems, multimedia information technology, information resources of the Internet) at all stages of design, development, exploitation to determine the residual operation life, namely: preliminary study, action principle choice, design of draft and technical projects, their optimization, preparation of design documentation and control information for automated production, comprehensive engineering analysis, etc. [14, 23 – 25].

### Methodology

To perform engineering calculations associated with the analysis of the strength of machines, mechanisms, constructions one uses both analytical and numerical methods in practice [4, 6, 19, 22].

The most commonly used method for analysis of stresses and deformations is Finite Element

Method (FEM) [2, 11, 17, 21]. It was first elaborated in the 50 years of the twentieth century to solve the problems of strength of materials. It is known that the strength of materials is the science of engineering calculation methods of machine elements, mechanisms and structures for strength, rigidity, stability and belongs to fundamental disciplines of general engineering training of specialists with higher technical education. This is the first discipline that establishes a link between fundamental scientific disciplines (physics, mathematics, theoretical mechanics) and applied problems and methods for their solution, resulting in the design of machines, building structures [8].

During the operation of machines and structures their elements are exposed to different forces – loads. To ensure the normal operation the structure must meet the required conditions of strength, rigidity and stability:

Strength is the ability of structure elements to withstand some load without destruction;

## РУХОМИЙ СКЛАД І ТЯГА ПОЇЗДІВ

Rigidity is the ability of structure elements to resist to deformation caused by external load; herewith the deformation should not exceed the permissible ones;

Stability is the ability of structure elements to maintain a certain original shape of the elastic equilibrium.

The main purpose of strength of materials is to provide structural strength. It occurs in the form of direct and inverse problem: the direct problem (projecting calculation) is to find reliable (in terms of strength) dimensions of the machine or structure elements, so that they could withstand a set load over the required period of time at the lowest cost; the inverse problem (checking calculation) is to check whether the element of already existing mechanism or structure meets the strength requirements in case of change of a set load, or it needs replacing or strengthening [8].

Thanks to scientists, since 1970, FEM has become increasingly popular among engineers of all specialties; at that time the first software FEM systems were developed. Now it is the main method of computational mechanics, which forms the basis of most modern software systems designed to perform engineering tasks in various fields [2, 11, 17, 21].

Thus, quality improvement of the mechanical equipment and structures must be connected primarily to reduction of their weight and cost, increased reliability and improvement of a number of other characteristics. Currently, the topical problem is combination of two mutually exclusive tendencies in the design: material savings on the one hand, and providing the necessary strength characteristics of structures on the other hand.

This can be achieved through the use of computer technology. Today it is impossible to create high-quality, reliable and competitive equipment without thorough engineering analysis of projected objects using modern software and making appropriate design decisions based on it. The engineering analysis means primarily the designer's study of stress-strain state (SSS) of designed object models, obtaining their dynamic and stability characteristics at constant and variable modes of external load. Assessment of SSS requires the knowledge about distribution of stresses in the elements of designed machines and structures, values of individual point displacement both due to static nature

of the external load, and in terms of the loads that vary over time.

Currently, due to the active implementation in engineering practice of computer technology, the most efficient approximate method for solving this class of applied problems in mechanics is the finite element method (FEM) [5, 10, 20].

FEM key idea is as follows: the solid medium (design model) is replaced with the discrete one by splitting it into finite elements (FE). The behaviour of each medium is described by a separate set of functions that represent the stress and displacement. Finite elements are connected with nodes; FE interaction is realised only through nodes. Located in a certain way, depending on object design, and secured in accordance with the boundary conditions, finite elements can adequately describe the diversity of models of parts and structures [9].

The end element can be imposed with external loads (concentrated and distributed forces and moments), which are applied to the element nodes and are called nodal loads.

When calculating using FEM first the displacements of model nodes are determined. The values of element internal forces are proportional to displacements of the element nodes. Proportionality factor is square matrix of element rigidity, whose number of lines equals to the number of degrees of element freedom (in general, this is the product of the number of degrees of node freedom by the number of element nodes). All other parameters of the final element, such as internal force, stress, displacement field, etc. are calculated on the basis of its nodal displacements.

Finite element method allows almost full automation of calculation of mechanical systems, but usually requires much more computing operations compared with the classical methods of mechanics. The current level of computing development opens up opportunities for the introduction of FEM in engineering practice [9].

FEM is implemented in many famous and widespread software products, providing strength calculation of models of machines, mechanisms and structures.

The complete finite-element analysis requires:

- Choosing the type of finite element (for the entire model or its individual parts), that will help adequately model the real structure;
- Building the model of a designed object in three dimensions;

## РУХОМИЙ СКЛАД І ТЯГА ПОЇЗДІВ

- Splitting the model into finite elements;
- Performing the full range of necessary calculations;
- Visualizing the results and interpreting them correctly to take the right design decisions.

**Findings**

In modern conditions to improve efficiency, achieve the highest quality and feasibility of results, among many of today's software packages, APM WinMachine came into widespread use. This is knowledge-intensive software, created on the basis of modern engineering methods of design, numerical methods of mechanics, mathematics and

modelling, which combines the experience of previous generations of designers, mechanical engineers and other professionals with the capabilities of computer technology, to the utmost adjusted for work on design and construction of facilities of engineering and construction industries [1, 9].

APM WinMachine software package allows the user to create three-dimensional models of random machines, mechanisms and structures (Fig. 3). Models consist of a rod, shell and solid elements; constructive models of shell and solid types can be imported from any third-party dimensional image editors, using a standard interchange format.

*a**b*

Fig. 3. Examples of creation of:  
*a* – solid models; *b* – model of sports complex bearing structure

## РУХОМИЙ СКЛАД І ТЯГА ПОЇЗДІВ

ARM WinMachine system consists of the following set of modules [1, 9]:

– APM Graph – flat drawing and graphics editor for execution of design documentation, which has convenient features of parametric geometry task (Fig. 4) [12, 16];

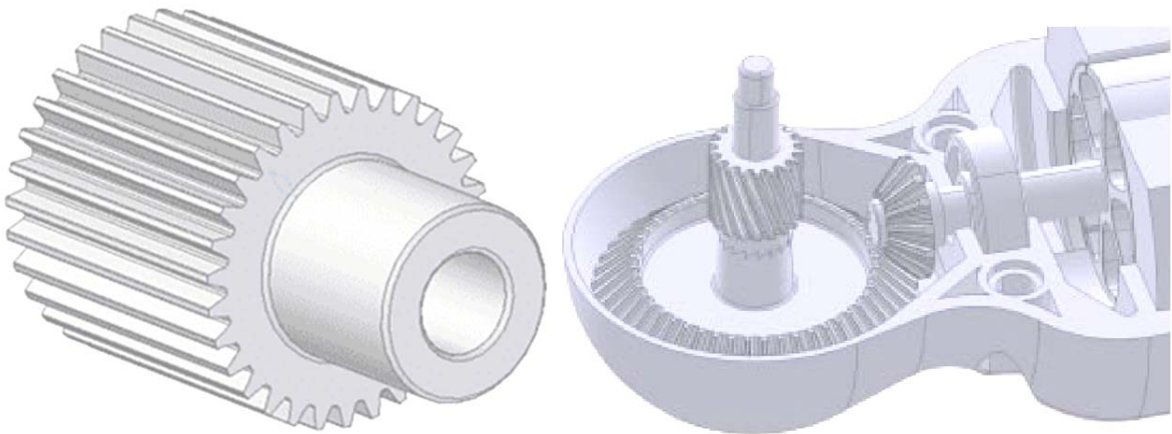
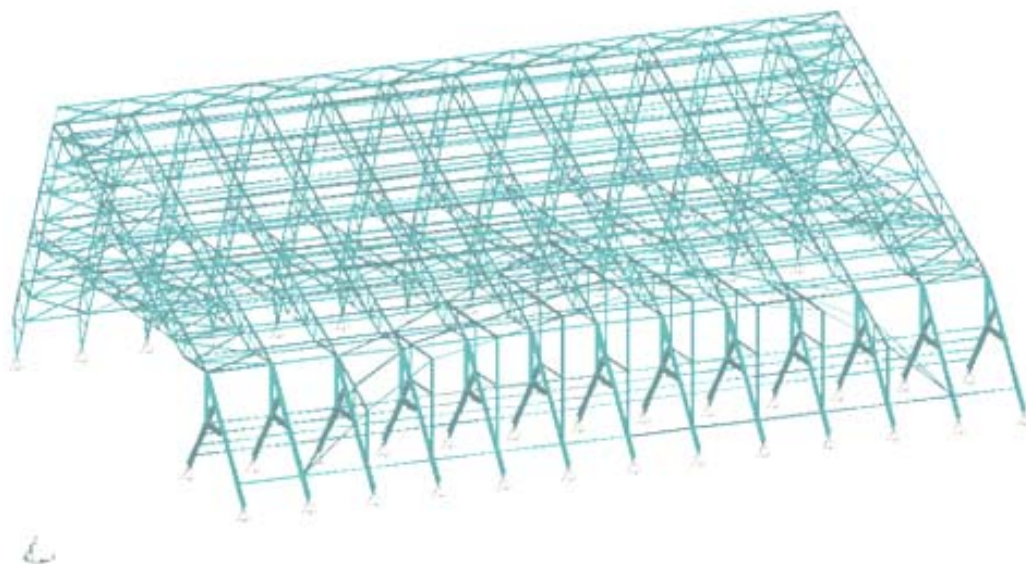
– APM Studio – module for creating three-dimensional surface and solid models with built-in generator for splitting into finite elements (Fig. 5 *a*, *b*) [1, 9];

– APM Mechanical Data – database of standard parts and components, reference data for general engineering (Fig. 5.);

– APM Material Data – module for storage and edit of material parameters;

– APM Construction Data – database of graphics on standard parts and elements of building structures (Fig. 5, *g*);

– APM Technology Data – database of standard information data for process design;

– APM Base – module for creating and editing databases;

– APM Book – electronic textbook «Fundamentals of Machine Design», which sets out the basic calculation methods implemented in ARM WinMachine System;

– APM Beam – module for calculation and design of beam construction elements;

– APM Structure3D – module for calculation and design of random structures, consisting of plate (Fig. 6), rod (Fig. 6 B), volume (Fig. 6) elements and their random combinations due to finite element method [1, 9].

*a*

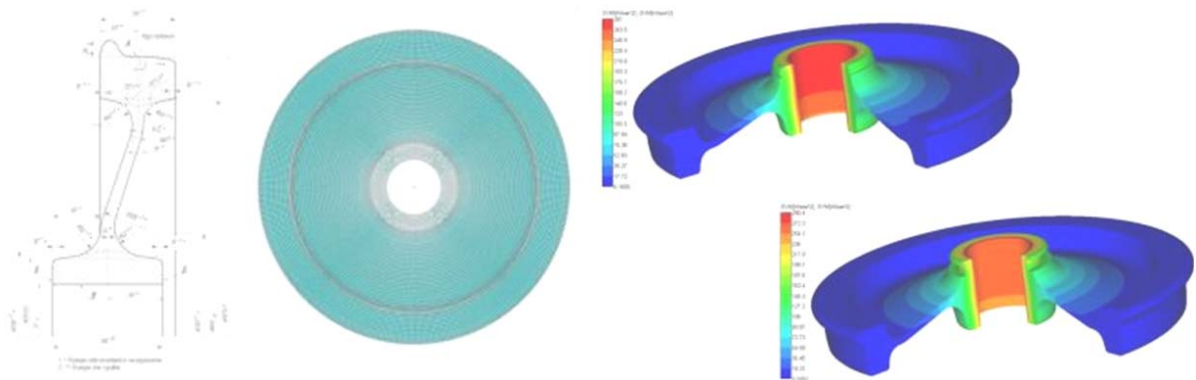

*b*

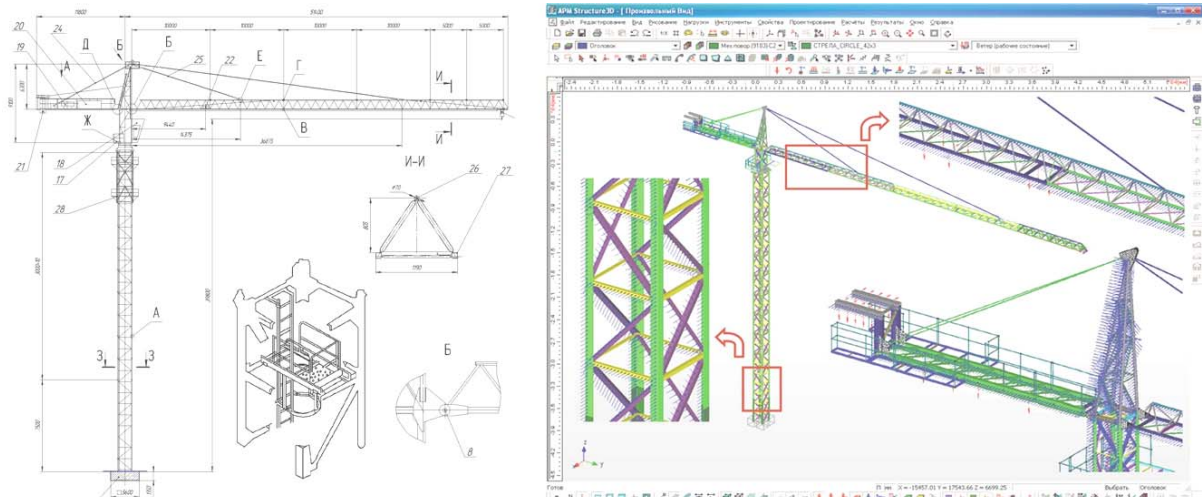
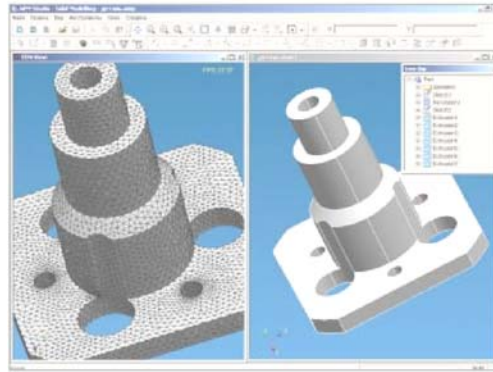

Fig. 4. Drawings and finite element model of:  
*a* – railway wheel; *b* – tower crane



РУХОМИЙ СКЛАД І ТЯГА ПОЇЗДІВ

*a*



*b*

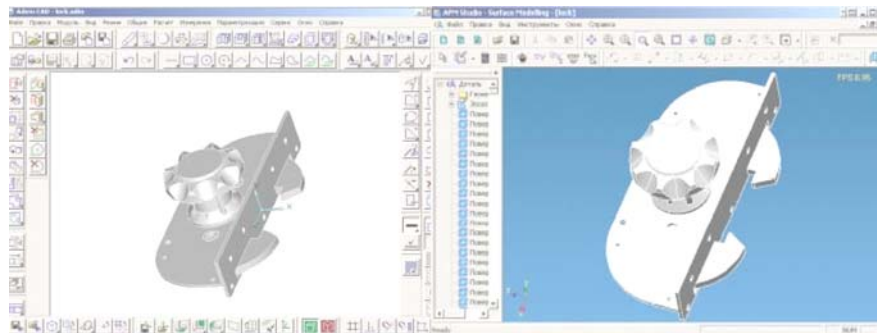

*c*

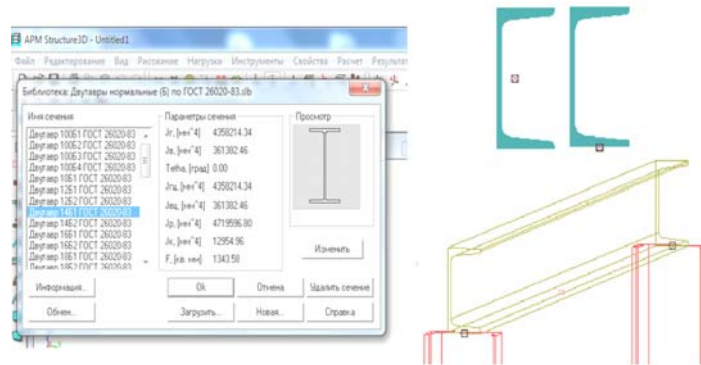

*d*

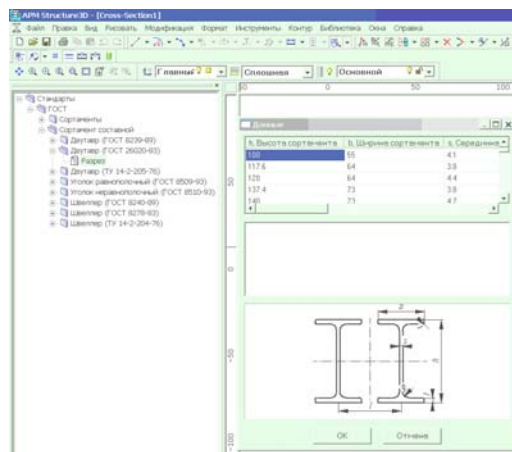

Fig. 5. Examples of display:

*a* – result of automatic work of FE-mesh generator in adaptive splitting mode; *b* – image transmission using the STEP format of three-dimensional model AdemCAD in dimensional projection module APM Studio; *c* – database and example of an anchor point of rolled section; *d* – example of inserting a section parametric model from the database



## РУХОМИЙ СКЛАД І ТЯГА ПОЇЗДІВ

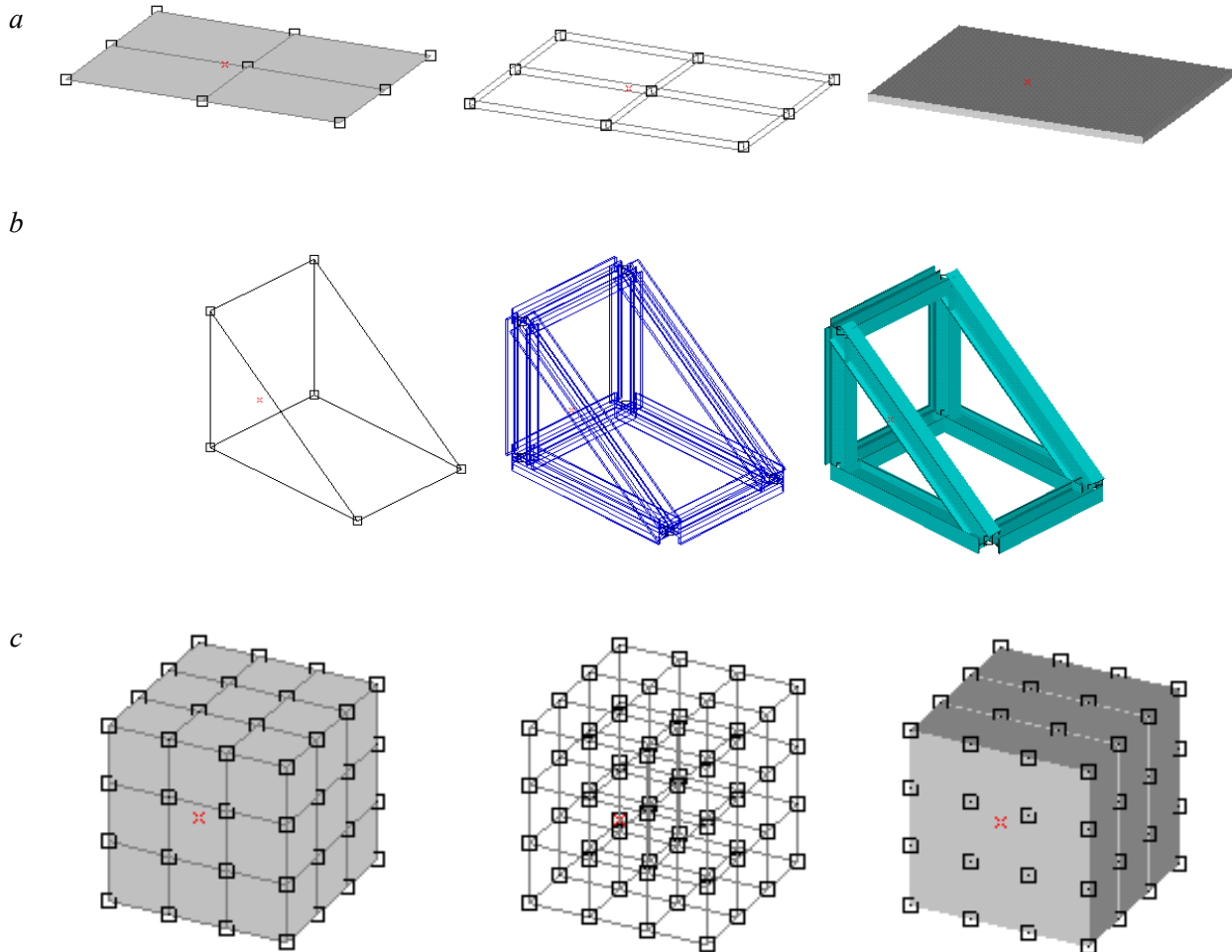

Fig. 6. Various types of element visualization:  
*a* – flat, frame, 3-D models of plates;  
*b* – wire, frame, 3-D models of rod;  
*c* – plate, frame, 3-D lighted models of volume element

ARM Structure3D module allows calculating the stress-strain state of structures in static mode, performing calculations for resistance and determination of natural frequencies [1, 9], analysing the behaviour of structures at random dynamic loads (Fig. 2, 7) [12];

– APM Joint – module for calculation and design of joints of machine parts and structural elements, which allows complex calculations of all types of threaded, welded, riveted joints and connections of rotation details;

– APM Trans – module for design of transmitting rotation intended to calculate all kinds of gears, as well as worm, belt and chain gear drives, to generate drawings of the gear elements in automatic mode;

– APM Shaft – module for calculation, analysis and design of shafts and axles;

– APM Bear – module for calculation of imperfect rolling bearings, allowing a comprehensive analysis of rolling-contact bearings of all known types;

– APM Plain – module for calculation and analysis of radial and thrust bearings operating under conditions of fluid and semi-fluid friction;

– APM Drive – module for calculation and design of random structure drive, planetary and wave gears. It allows complex calculation of kinematic characteristics and design of drive as a whole and its individual elements with automatic generation of drawings of parts and assemblies including the body;

– APM Spring – module for calculation and design of springs and other spring-elastic elements of machines (Fig. 8).

РУХОМИЙ СКЛАД І ТЯГА ПОЇЗДІВ

*a*

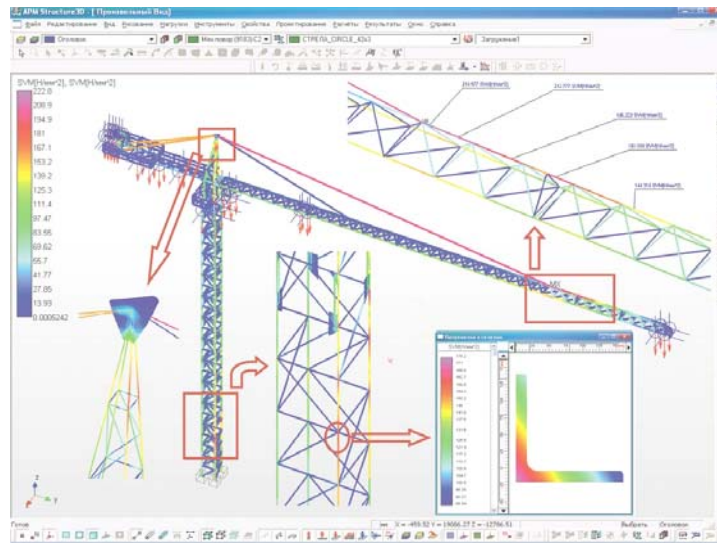

*b*

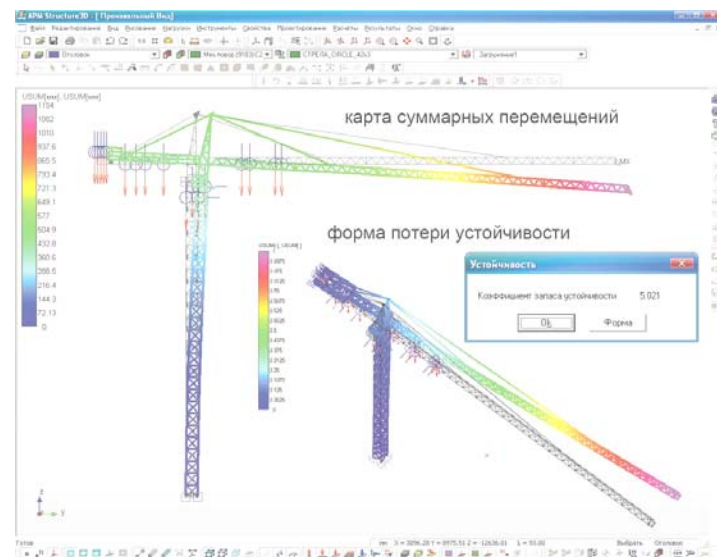

*c*

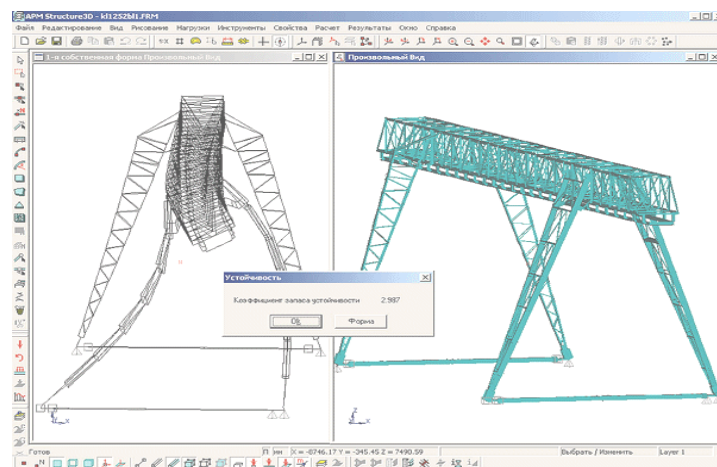

Fig. 7. Charts of metal structure calculation results:  
*a* – distribution of equivalent stresses of tower crane; *b* – distribution of tower crane displacements;  
*c* – buckling mode and chart of frequencies of container gantry crane free oscillation

## РУХОМИЙ СКЛАД І ТЯГА ПОЇЗДІВ

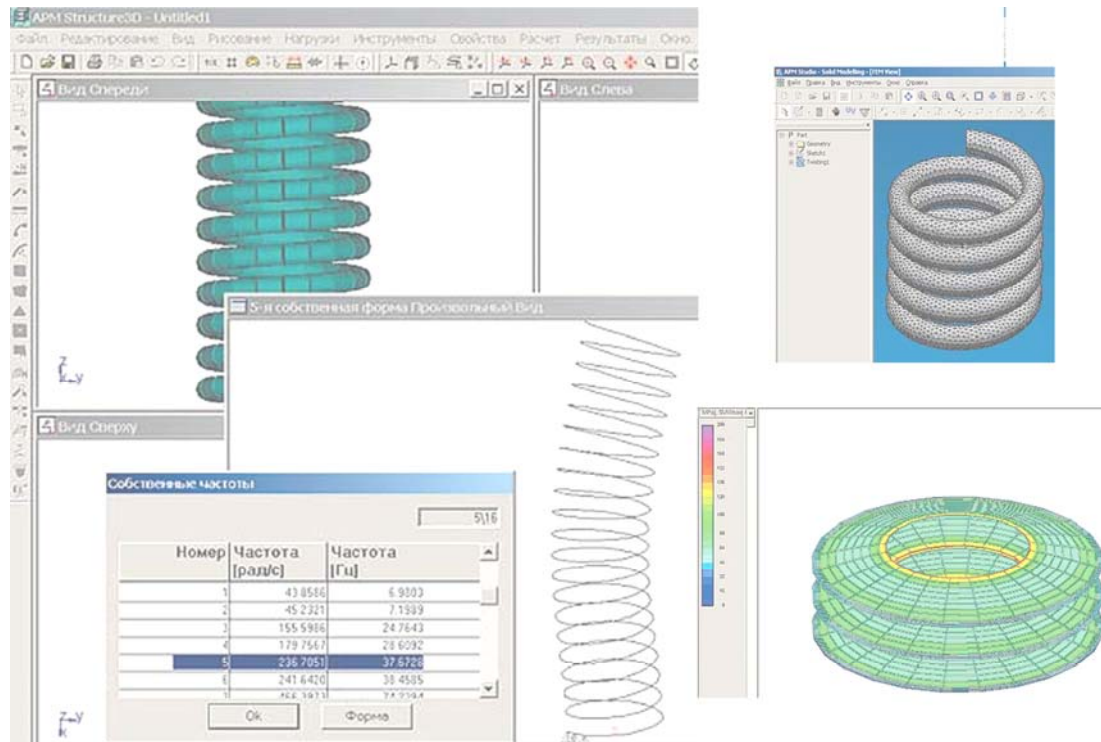

Fig. 8. Models of spring-elastic elements

– APM Car, APM Slider – modules for calculation and design of camshaft mechanisms with automatic generation of drawings and linkage mechanisms of random structure;

– APM Screw – module for calculating imperfect forward motion gears; able to calculate the screw shift gear, ball-screw and screw planetary gears;

– APM Technology – module for process design.

APM WinMachine software is flexible, reliable means of design and analysis; runs on most popular operating systems of computers – from PC to workstations and supercomputers. Despite the fact that APM WinMachine program has a variety of sophisticated options, its organizational structure and user «friendly» graphical interface makes learning and application of the program very convenient. At the same time the program is completed with documentation that enables to deal with the order of implementation of complex works online. The system «menu» includes «intuitive» features, helping the user to control the program effectually. Output data can be entered using the manipulator «mouse», keyboard or by combin-

ing these two options [1, 9].

The easiest communication way with APM WinMachine package is the use of menu system, called the user graphical interface (Fig. 9 a).

In all versions of APM WinMachine software package the on-screen menu (Fig. 9, a) includes windows, among which the key ones are as follows [1, 9]:

1. Utility Menu – contains service functions used during the entire session on APM WinMachine software, such as file and image management and settings; this «menu» also provides the program exit.

2. Input Window – allows direct entry of embedded commands.

3. Standard Toolbar – contains buttons for frequently used software commands.

4. Additional Toolbar – contains commands and functions of APM WinMachine (Fig. 9, b).

5. Graphic Output Window – display of the main relevant information on current work (Fig. 9, c).

6. Quick Access Toolbar – located below the graphic output window, helps perform online operations.

## РУХОМИЙ СКЛАД І ТЯГА ПОЇЗДІВ

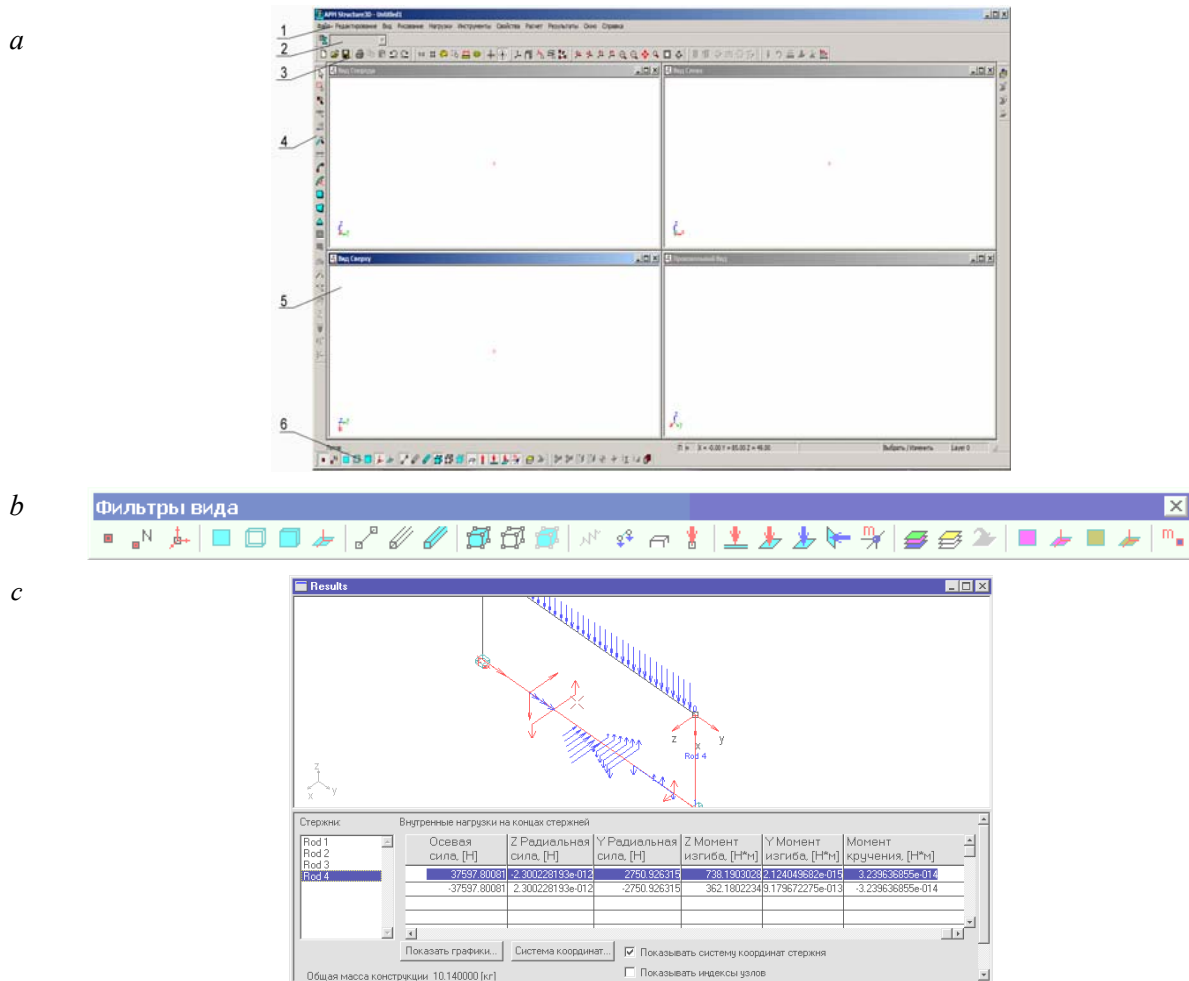

Fig. 9. General view of:

*a* – menu system; *b* – toolbar «View filters»;  
*c* – dialog window showing displacement and load at nodes

Thus, APM WinMachine software package helps get the results (Fig. 10, 11), the main of which are as follows [3]:

- The static calculation results: structure node displacements (linear and angular); load at the ends of rods, at the nodes of plates and volume elements; epures of force factors for the whole structure; tensions existing in rods, plates and volume elements; stress distribution in random section of the rod; design parameters specific to a single beam, such as bending moments, torsion, lateral and axial force, angles of bending, twisting, deformation and strain along the beam length. All these options are in the form of graphs displayed in the coordinate system of the rod; reactions (forces and moments) acting in bearing supports; structure weight.

- Nodal displacement and load at the ends of rods, at the nodes of plates and volume elements are displayed in the form of table.

- The results of nonlinear calculation are the same parameters as for linear static calculation.

- The result of the strain calculation are the same options as for the static calculation, plus the critical buckling load parameter of the 2nd kind and the buckling mode.

- The result of calculation of the natural frequencies include: a few first frequencies of the structure free oscillations; corresponding forms of free oscillations.

- Calculation results for structure forced oscillations are as follows: structure node displacements; stresses existing in rods, plates and volume elements; reaction in the bearing supports; free frequencies and free forms of oscillations.



## РУХОМИЙ СКЛАД І ТЯГА ПОЇЗДІВ

– Calculation of load capacity of metal structure rod elements is performed for structural elements and in this version of APM Structure3D is implemented in accordance with the requirements of SNIP «Steel structures». Rod element strength/resistance can also be tested by classical methods of strength of materials.

– The result of the contact interaction calculation is the stress-strain state of structural model and the distribution chart of normal and tangential forces, mutual penetration and state of contact elements in the contact area.

– The result of the stability calculation is the structure stability factor and the buckling mode.

*a**b**c*

Fig. 10. Example of bus carcass calculation:  
*a* – general view of calculation model, *b* – chart of equivalent stress distribution;  
*c* – chart of displacement distribution

## РУХОМИЙ СКЛАД І ТЯГА ПОЇЗДІВ

*a**b**c*

Fig. 11. Mobile track crane boom:  
*a* – calculation model; *b* – chart of equivalent stress distribution;  
*c* – chart of the total linear displacement distribution

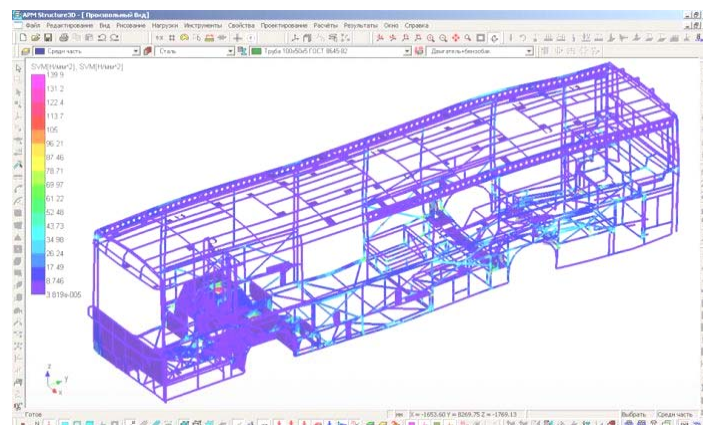
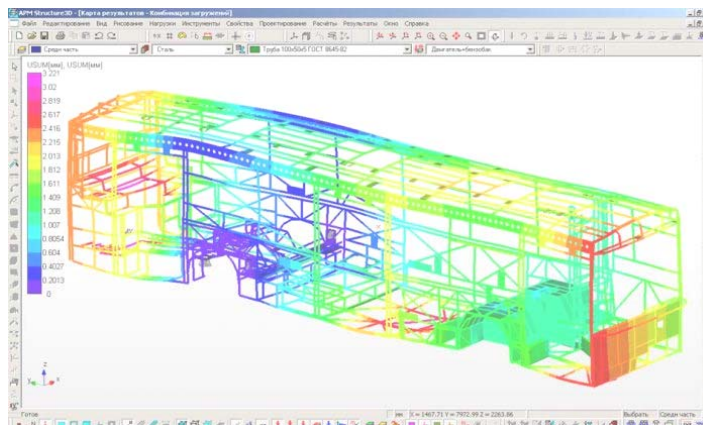
## РУХОМИЙ СКЛАД І ТЯГА ПОЇЗДІВ

*Analysis of results.* APM WinMachine system has a wide range of options for displaying the results. Such calculation results as stress, displacement, force, safety factor, etc. in rods, plates and volume elements can be displayed as a chart of results [1, 3, 7, 12, 16]. Chart of results is a three-dimensional structure, painted in colours in accordance with the values of the selected component of the results on the surface. Colour charts for distribution of equivalent stresses (Fig. 2 *b*, 4 *a*, 7 *a*, 10 *b*, 11 *b*) and displacement (Fig. 2 *c*, 7 *b*, 10 *c*, 11 *c*) internal efforts, safety factor and others allow accurate and quick identification of the most dangerous places in the structure. The program also provides an opportunity to «look» inside the elements and see the resulting distribution of internal force factors. For more complete presentation of results the user has an opportunity to build epures of various force factors on the structure 3D-model, to display reactions in support points, to evaluate the general parameters such as weight, maximum stress, displacement, to produce a summary table of output by metal structure elements.

### Originality and practical value

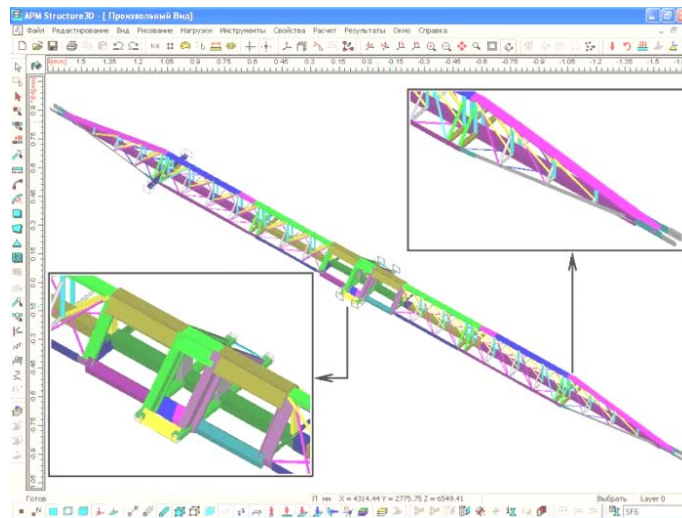
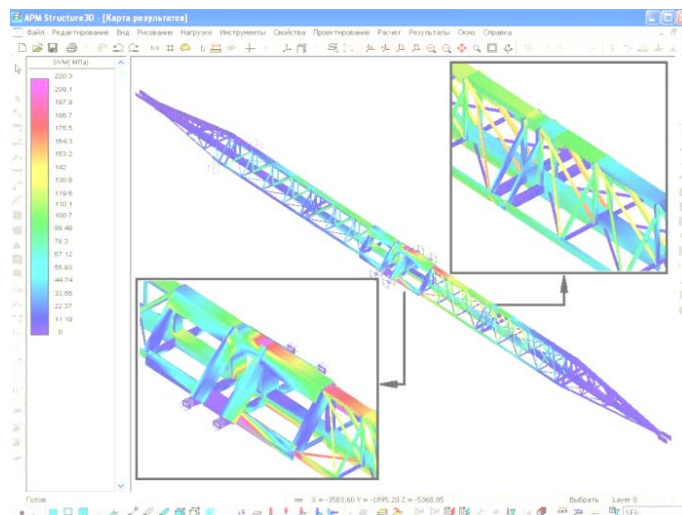
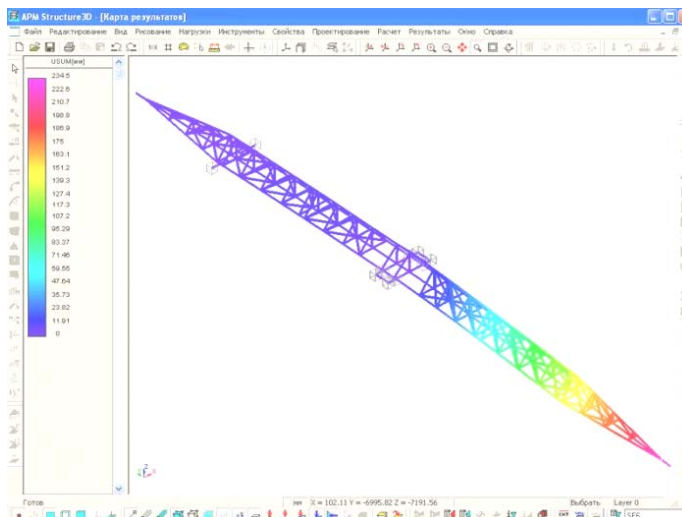
Compared with other software systems, APM WinMachine popularity is explained by easy mastering of the system, quick implementation both in training and in production process [1, 3, 7, 12, 16], due to the fact that there is:

- the largest number of nodes;
- user-friendly interface of all system modules;
- wider range of operations within both each module and the entire software system as a whole;
- system building based on existing national standards, regulations and principles of design;
- possibility of calculations simultaneously in several modules, which speeds up the work process, reduces the risk of erroneous data entry.

In addition, organizational structure, «friendly» graphical interface and accessible language make learning and use of the program very convenient. These and other factors actually reduce the time for project implementation, emphasize the relevance and the practical importance of WinMachine software system, which is appreciated by its users.

The paper considered the aspects, which are unexplored at present, associated with the current state and prospects of development of industrial production, the use of software package for design

and calculations in the mechanical industry. The result of the work is the justification of software application for solving problems that are aimed at using research findings for various practical tasks leading to development of new equipment, machinery, mechanisms, etc. to obtain a direct economic benefit in specific fields of mechanical engineering.

### Conclusions

The end product of mechanical engineering is machinery, equipment, appliances, instruments and services for all industries without exception. To conduct the whole complex of calculations both for separate kit parts, assemblies, mechanisms and for finished products of kit parts, among many of today's software packages, APM WinMachine came into widespread use. Its use for performance and design of machine parts and various types of their joints and for strength analysis of structures is justified; it actually reduces the problem solution time.

This will allow producing the equipment up to the best analogues, optimal in price, power consumption, etc., and as a result, competitive at the world market.

### LIST OF REFERENCE LINKS

1. APM Structure3D. Система расчёта и проектирования деталей и конструкций методом конечных элементов. Версия 9.2: рук-во пользователя [Electronic resource] – Available at: <http://www.apm.ru>. – Title from the screen. – Accessed : 10.02.2016.
2. Агапов, В. П. Метод конечных элементов в статике, динамике и устойчивости пространственных тонкостенных подкрепленных конструкций / В. П. Агапов. – Москва : АСВ, 2000. – 152 с.
3. АО «Калугапутьмаш» [Electronic resource]. – Available at: <http://www.kalugaputmash.ru>. – Title from the screen. – Accessed : 10.02.2016.
4. Бате, К. Численные методы анализа и метод конечных элементов / К. Бате, Е. Вильсон. – Москва : Стройиздат, 1982. – 448 с.
5. Галлагер, Р. Метод конечных элементов. Основы / Р. Галлагер ; [пер. с англ. В. М. Картвелишвили]. – Москва : Мир, 1984. – 428 с.
6. Дарков, А. В. Строительная механика / А. В. Дарков, Н. Н. Шапошников. – Москва : Высш. шк., 1986. – 462 с.

## РУХОМИЙ СКЛАД І ТЯГА ПОЇЗДІВ

7. Демиковский машиностроительный завод [Electronic resource]. – Available at: <http://www.dmzavod.ru>. – Title from the screen. – Accessed : 10.02.2016.
8. Дистанційне навчання. Опір матеріалів [Electronic resource] / каф. «Будівельна механіка». – Available at: <http://www.moodle.diit.edu.ua>. – Title from the screen. – Accessed : 10.02.2016.
9. Замрий, А. А. Проектирование и расчет методом конечных элементов трехмерных конструкций в среде APM Structure3D / А. А. Замрий. – Москва : АПМ, 2006. – 288 с.
10. Зенкевич, О. Метод конечных элементов в технике / О. Зенкевич ; [пер. с англ. А. В. Васильева, В. М. Курочкина] ; под ред. Б. Е. Победри. – Москва : Мир, 1975. – 544 с.
11. Иванов, Б. Э. Решение задач динамики и устойчивости строительных конструкций методом конечных элементов / Б. Э. Иванов. – Москва : МИСИ, 1990. – 288 с.
12. Коновалов, Д. Использование программного комплекса APM WinMachine для исследования остаточного ресурса порталных кранов / Д. Коновалов, А. Дарюхин // САПР и графика. – 2008. – № 3. – С. 84–87.
13. Крилов, І. В. Інформаційні технології: теорія і практика / І. В. Крилов. – Київ : Центр, 2006. – 128 с.
14. Мямлін, С. В. Визначення впливу показників тертя в системі «кузов-візок» на динаміку вантажного вагона / С. В. Мямлін, Л. О. Недужа, А. О. Швець // Наука та прогрес транспорту. – № 2 (50). – 2014. – С. 152–163. doi: 10.15802/stp2014/23792.
15. Промисловість. Географія основних галузей промисловості світу (енергетика, металургія, машинобудування, хімічна промисловість, лісова та деревообробна промисловість, легка промисловість) [Electronic resource] / підр. – Available at: <http://ukrmap.su/uk-g11/-1345.html>. – Title from the screen. – Accessed : 10.02.2016.
16. Прочностной расчет железнодорожного колеса с кольцевой канавкой на боковой поверхности ступицы. АПМ: Расчеты механики и прочно-сти конструкций. [Electronic resource] – Available at: [http://cae.apm.ru/galereya\\_vipo-lnennih-proektov/mashinostroenie/avto\\_i\\_geleznodorognyi\\_transport/geleznodorognoe\\_koleso](http://cae.apm.ru/galereya_vipo-lnennih-proektov/mashinostroenie/avto_i_geleznodorognyi_transport/geleznodorognoe_koleso). – Title from the screen. – Accessed : 10.02.2016.
17. Синицин, А. П. Метод конечных элементов в динамике сооружений / А. П. Синицин. – Москва : Стройиздат, 1978. – 232 с.
18. Склад і структура промислового виробництва та актуальні проблеми його розвитку [Electronic resource]. – Available at: <http://w-ww.infolibrary.com.ua/books-text-6010.html>. – Title from the screen. – Accessed : 10.02.2016.
19. Смирнов, А. Ф. Методы расчета стержневых систем, пластин и оболочек с использованием ЭВМ / А. Ф. Смирнов. – Москва : Стройиздат, 1976. – 248 с.
20. Тимошенко, С. П. Механика материалов / С. П. Тимошенко, Дж. Гере ; [пер. с англ. Л. Г. Корнейчук] ; под ред. Э. И. Григолюка. – Москва : Мир, 1976. – 670 с.
21. Хечумов, Р. А. Применение метода конечных элементов к расчету конструкций / Р. А. Хечумов. – Москва : АСВ, 1994. – 354 с.
22. Clough, R. Dynamics of Structure / R. Clough, J. Penzien. – New-York : McGraw-Hill Book Co., 1975. – 634 с.
23. Determination of Dynamic Performance of Freight Cars Taking Into Account Technical Condition of Side Bearers / S. Myamlin, L. Neduzha, O. Ten, A. Shvets // Наука та прогрес транспорту. – № 1 (43). – 2013. – С. 162–169. doi: 10.15802/stp-2013/9589.
24. Myamlin, S. V. Experimental Research of dynamic qualities of freight cars with bogies of different designs / S. V. Myamlin, O. O. Ten, L. O. Neduzha // Наука та прогрес транспорту. – № 3 (51). – 2014. – С. 136–145. doi: 10.15802/stp2014/25921.
25. Research of friction indices influence on the freight car dynamics / S. Myamlin, L. Neduzha, O. Ten, A. Shvets // ТЕКА Commission of Motorization and Power Industry in Agriculture. – 2013. – Vol. 13, № 4. – P. 159–166.

Л. О. НЕДУЖА<sup>1\*</sup>, А. О. ШВЕЦЬ<sup>2\*</sup>

<sup>1\*</sup>Каф. «Будівельна механіка», Дніпропетровський національний університет залізничного транспорту імені академіка В. Лазаряна, вул. Лазаряна, 2, Дніпропетровськ, Україна, 49010, тел. +38 (067) 810 51 65, ел. пошта nlorhen@i.ua, ORCID 0000-0002-7038-3006

<sup>2\*</sup>СКТБ МСУБ, Дніпропетровський національний університет залізничного транспорту імені академіка В. Лазаряна, вул. Лазаряна, 2, Дніпропетровськ, Україна, 49010, тел. +38 (050) 214 14 19, ел. пошта angela\_shvets@ua.fm, ORCID 0000-0002-8469-3902



РУХОМИЙ СКЛАД І ТЯГА ПОЇЗДІВ

## ЗАСТОСУВАННЯ ПРОГРАМНОГО КОМПЛЕКСУ ARM WINMACHINE ПРИ ПРОЕКТУВАННІ ТА РОЗРАХУНКАХ У МАШИНОБУДУВАННІ

**Мета.** Для проведення досліджень на всіх етапах проектування, розробки, експлуатації, визначення остаточного ресурсу (а саме: попереднього дослідження, вибору принципів дії, розробок ескізного та технічного проектів, їх оптимізації, підготовки конструкторської документації та керуючої інформації для автоматизованих виробництв, всебічного інженерного аналізу) необхідно використовувати найсучасніші комп'ютерні технології. Їх використання дозволяє не лише відтворювати дані й відомості тим чи іншим способом, а також надає можливість ефективно та безпосередньо взаємодіяти з інформаційним об'єктом, що створюється або демонструється. Метою дослідження є аналіз теоретичних підходів та механізмів здійснення практичних розрахунків у галузях промисловості для вирішення сучасних задач за допомогою програмних комплексів. **Методика.** При виконанні інженерних розрахунків, пов'язаних із аналізом міцності машин, механізмів, конструкцій, на практиці використовують як аналітичні, так і чисельні методи. Найбільшого поширення при аналізі напружено-деформованого стану моделей об'єктів, отримання їх динамічних характеристик і характеристик стійкості при постійних та змінних режимах зовнішнього навантаження отримав метод кінцевих елементів, який реалізовано в багатьох відомих й широко розповсюджених програмних продуктах, що забезпечують міцнісний розрахунок моделей машин, механізмів, конструкцій. **Результати.** Обґрунтовано використання розглянутого сучасного програмного комплексу для проектування деталей машин й різноманітних видів їх з'єднань та міцнісного аналізу конструкцій. Кольорові карти розподілу напружень, переміщень, внутрішніх зусиль, коефіцієнтів запасу міцності та ін. дозволяють дуже точно і швидко визначити найбільш небезпечні місця в конструкції. Програма забезпечує можливість «заглянути» всередину елементів та побачити розподіл виникаючих внутрішніх силових чинників. **Наукова новизна.** Розглянуто недосліджені на даний період аспекти, що пов'язані з сучасним станом та перспективами розвитку промислового виробництва, використання програмного комплексу при проектуванні та розрахунках у машинобудівній галузі. Розроблено обґрунтування застосування програмного комплексу для розв'язання задач, які спрямовані на використання результатів досліджень для різних практичних завдань у конкретних галузях машинобудування. **Практична значимість.** У порівнянні з іншими програмними комплексами популярність даного полягає у легкому засвоєнні системи, швидкому впровадженні як у навчальний, так і у виробничий процеси. Організаційна структура й «дружній» графічний інтерфейс, доступність мови роблять вивчення та застосування програми дуже зручним. Ці та інші чинники реально скорочують час на реалізацію проектів, підкреслюють актуальність та практичне значення програмного комплексу, що повинно бути гідно оцінено його користувачами при проведенні подальших досліджень.

*Ключові слова:* сучасний програмний комплекс; машинобудування; машина; механізм; конструкція; інженерний розрахунок; міцність

Л. А. НЕДУЖАЯ<sup>1\*</sup>, А. А. ШВЕЦ<sup>2\*</sup>

<sup>1\*</sup>Каф. «Строительная механика», Днепропетровский национальный университет железнодорожного транспорта имени академика В. Лазаряна, ул. Лазаряна, 2, Днепропетровск, Украина, 49010, тел. +38 (067) 810 51 65, эл. почта nloghen@i.ua, ORCID 0000-0002-7038-3006

<sup>2\*</sup>СКТБ МСУБ, Днепропетровский национальный университет железнодорожного транспорта имени академика В. Лазаряна, ул. Лазаряна, 2, Днепропетровск, Украина, 49010, тел. +38 (050) 214 14 19, эл. почта angela\_shvets@ua.fm, ORCID 0000-0002-8469-3902

## ПРИМЕНЕНИЕ ПРОГРАММНОГО КОМПЛЕКСА ARM WINMACHINE ПРИ ПРОЕКТИРОВАНИИ И РАСЧЕТАХ В МАШИНОСТРОЕНИИ

**Цель.** Для проведения исследований на всех этапах проектирования, разработки, эксплуатации, определения остаточного ресурса (а именно: предварительного исследования, выбора принципов действия, разработок эскизного и технического проектов, их оптимизации, подготовки конструкторской документации

## РУХОМИЙ СКЛАД І ТЯГА ПОЇЗДІВ

и управляющей информации для автоматизированных производств, всестороннего инженерного анализа) необходимо использование самых современных компьютерных технологий. Их использование позволяет не только воспроизводить данные и сведения тем или иным способом, а также предоставляет возможность эффективно и непосредственно взаимодействовать с информационным объектом, который создается или демонстрируется. Целью исследования является анализ теоретических подходов и механизмов осуществления практических расчетов в отраслях промышленности для решения современных задач с помощью программных комплексов. **Методика.** При выполнении инженерных расчетов, связанных с анализом прочности машин, механизмов, конструкций на практике используют как аналитические, так и численные методы. Наибольшее распространение при анализе напряженно-деформированного состояния моделей объектов, получения их динамических характеристик и характеристик устойчивости при постоянных и переменных режимах внешней нагрузки получил метод конечных элементов, реализованный во многих известных и широко распространенных программных продуктах, обеспечивающих прочностной расчет моделей машин, механизмов, конструкций. **Результаты.** Обосновано использование рассматриваемого современного программного комплекса для проектирования деталей машин и различных видов их соединений и прочностного анализа конструкций. Цветные карты распределения напряжений, перемещений, внутренних усилий, коэффициентов запаса прочности и др. позволяют очень точно и быстро определять наиболее опасные места в конструкции. Программа обеспечивает возможность «заглянуть» внутрь элементов и увидеть распределение возникающих внутренних силовых факторов. **Научная новизна.** Рассмотрены неисследованные на данный период аспекты, связанные с современным состоянием и перспективами развития промышленного производства, использования программного комплекса при проектировании и расчетах в машиностроительной отрасли. Разработано обоснование применения программного комплекса для решения задач, направленных на использование результатов исследований для различных практических задач в конкретных отраслях машиностроения. **Практическая значимость.** По сравнению с другими программными комплексами популярность данного заключается в легком усвоении системы, быстром его внедрении как в учебный, так и в производственный процессы. Организационная структура и «дружественный» графический интерфейс, доступность языка делают изучение и применение программы очень удобным. Эти и другие факторы реально сокращают время на реализацию проектов, подчеркивают актуальность и практическое значение программного комплекса, что должно быть достойно оценено его пользователями при проведении дальнейших исследований.

*Ключевые слова:* современный программный комплекс; машиностроение; машина; механизм; конструкция; инженерный расчет; прочность

## REFERENCES

1. APM Structure3D. *Sistema rascheta i proyektirovaniya detaley i konstruktsiy metodom konechnykh elementov. Versiya 9.2: rukovodstvo polzovatelya* (APM Structure3D. The system of calculation and design of components and structures using finite element method. Version 9.2. User's guid)]. Available at: <http://www.apm.ru> (Accessed 10 February 2016).
2. Agapov V.P. *Metod konechnykh elementov v statike, dinamike i ustoychivosti prostranstvennykh tonkostennykh podkreplennykh konstruktsiy* [The finite element method in statics, dynamics and stability of the space thin-walled reinforced constructions]. Moscow, ACB Publ., 2000. 152 p.
3. AO «Kalugaput mash» (LC «Kalugaput mash»). Available at: <http://www.kalugaput mash.ru> (Accessed 10 February 2016).
4. Bate K. *Chislennyye metody analiza i metod konechnykh elementov* [Numerical methods of analysis and finite element method]. Moscow, Stroyizdat Publ., 1982. 448 p.
5. Gallager R. *Metod konechnykh elementov. Osnovy* [The finite element method. Foundations]. Moscow, Mir Publ., 1984. 428 p.
6. Darkov A.V., Shaposhnikov N.N. *Stroitel'naya mekhanika* [Building mechanics]. Moscow, High School Publ., 1986. 462 p.
7. *Demikhovskiy mashinostroitel'nyy zavod* (Demikhovskiy Machinery Plant). Available at: <http://www.dmzavod.ru> (Accessed 10 February 2016).
8. *Dystanciine navchannia. Opir materialiv* (Distance Learning. Strength of Materials). Available at: <http://www.moodle.diit.edu.ua> (Accessed 10 February 2016).
9. Zamriy A.A. *Proyektirovaniye i raschet metodom konechnykh elementov trekhmernykh konstruktsiy v srede APM Structure3D* [Design and finite element analysis of three-dimensional structures in the APM environment Structure 3D]. Moscow, APM Publ., 2006. 288 p.

## РУХОМИЙ СКЛАД І ТЯГА ПОЇЗДІВ

10. Zenkevich O. *Metod konechnykh elementov v tekhnike* [The finite element method in the technique]. Moscow, Mir Publ., 1975. 544 p.
11. Ivanov B.E. *Resheniye zadach dinamiki i ustoychivosti stroitelnykh konstruksiy metodom konechnykh elementov* [The solution of problems of dynamics and stability of building structures using finite element method]. Moscow, IISS Publ., 1990. 288 p.
12. Konovalov D., Daryukhin A. Ispolzovaniye programmnoho kompleksa APM WinMachine dlya issledovaniya ostatochnogo resursa portalnykh kranov [Using APM WinMachine software package for the study of the residual resource of gantry cranes]. *SAPR i grafika – CAD and Graphics*, 2008, issue 3. pp. 84-87.
13. Krylov I.V. *Informaciini tekhnologii: teoriia i praktyka* [Information Technology: Theory and Practice]. Moscow, Center Publ., 2006. 128 p.
14. Myamlin S.V., Neduzha L.A., Shvets A.A. *Vyznachennia vplyvu pokaznykiv tertia v systemi «kuzov-vizok» na dynamiku vantazhnoho vahona* [Determining the impact of friction parameters in the «body-bogie» on the dynamics of freight cars]. *Nauka ta prohres transportu – Science and Transport Progress*, 2014, no. 2 (50), pp. 152-163. doi: 10.15802/stp2014/23792.
15. Promyslovist. Heoghrافیa osnovnykh haluzei promyslovosti svitu (enerhetyka, metalurhiia, mashynobuduvannia, khimichna promyslovist, lisova ta derevoobrobna promyslovist, lehka promyslovist (Industry. Location of key industries in the world (energy, metallurgy, chemical industry, timber and woodworking industry, light industry)). Available at: <http://ukrmap.su/uk-g11/1345.html> (Accessed 10 February 2016).
16. Prochnostnoy raschet zheleznodorozhnogo koleasa s koltsevoy kanavkoy na bokovoy poverkhnosti stupitsy. APM: Raschety mekhaniki i prochnosti konstruksiy (Strength calculation railway wheel with an annular groove on the lateral surface of the hub. APM: Calculations mechanics and strength of structures). Available at: [http://cae.apm.ru/galereya\\_vipolnennih\\_proektov/mashinostroenie/avto\\_i\\_geleznodorognyy\\_transport/geleznodorognoe\\_koleso](http://cae.apm.ru/galereya_vipolnennih_proektov/mashinostroenie/avto_i_geleznodorognyy_transport/geleznodorognoe_koleso) (Accessed 10 February 2016).
17. Sinitsin A.P. *Metod konechnykh elementov v dinamike sooruzheniy* [The finite element method in dynamics of structures]. Moscow, Stroyizdat Publ., 1978. 232 p.
18. *Sklad i struktura promyslovoho vyrobnytstva ta aktualni problemy yoho rozvytku* (Composition and structure of industrial production and actual problems of development). Available at: <http://www.info-library.com.ua/books-text-6010.html> (Accessed 10 February 2016).
19. Smirnov A.F. *Metody rascheta sterzhnevyykh sistem, plastin i obolochek s ispolzovaniyem EVM* [Methods of calculating rod, plates and shells with using computers]. Moscow, Stroyizdat Publ., 1976. 248 p.
20. Timoshenko S.P., Dzh. Gere. *Mekhanika materialov* [Mechanics of materials]. Moscow, Mir Publ., 1976. 670 p.
21. Khechumov R.A. *Primeneniye metoda konechnykh elementov k raschetu konstruksiy* [The finite elements method application for calculating of structures]. Moscow, DIA Publ., 1994. 354 p.
22. Clough R., Penzien J. *Dynamics of Structure*. New-York, McGraw-Hill Book Co. Publ., 1975. 634 p.
23. Myamlin S., Neduzha L., Ten O., Shvets A. Determination of Dynamic Performance of Freight Cars Taking Into Account Technical Condition of Side Bearers. *Nauka ta prohres transportu – Science and Transport Progress*, 2013, no. 1 (43), pp. 162-169. doi: 10.15802/stp2013/9589.
24. Myamlin S.V., Neduzha L.A., Ten O.O. Experimental Research of dynamic qualities of freight cars with bogies of different designs. *Nauka ta prohres transportu – Science and Transport Progress*, 2014, no. 3 (51), pp. 136-145. doi: 10.15802/stp2014/25921.
25. Myamlin S., Neduzha L., Ten O., Shvets A. Research of friction indices influence on the freight car dynamics. *TEKA Commission of Motorization and Power Industry in Agriculture*, 2013, no. 4 (13), pp. 159-166.

*Prof. Yu. V. Zelenko, Sc. Tech. (Ukraine); Prof. V. Ye. Volkova, Sc. Tech. (Ukraine) recommended this article to be published*

Accessed: Feb., 02. 2016

Received: Apr., 24. 2016